

Stabilized Telehandlers

P50.18





PERFORMANCE AND FEATURES	P50.18 PLUS	P50.18 CSTOP	
Performance			
Total unladen weight (kg)	13300	13650	
Maximum capacity (kg)	5000	5000	
Lifting height (m)	17,5	17,5	
Maximum reach (m)	13,5	13,5	
Maximum operating height (m)	9,2	9,2	
Maximum operating reach (m)	3,7	3,7	
Capacity at maximum height (kg)	2500	2500	
Capacity at maximum reach (kg)	750	750	
Lateral boom movement (mm)	± 445	± 445	
Tilting correction (%)	± 8	± 8	
Boom sections	4	4	
PowerTrain			
Turbo motor	PERKINS 904J	PERKINS 904J	
Displacement/cylinders	3600/4	3600/4	
Engine Power (kW/HP)	85,9/115	85,9/115	
Anti-pollution technology	STAGE V, SCR+DPF+DOC	STAGE V, SCR+DPF+DOC	
Reversible fan	●	●	
Maximum speed (km/h)	40	40	
Fuel tank (l)	140	140	
AdBlue tank (l)	18	18	
Hydrostatic transmission	● - 2V	Top - 2V	
EPD	Plus	Plus	
Auto-revving joystick	●	●	
Axles - Reducers	Drop portal - RR700	Drop portal - RR700	
Machine brakes	Dry discs	Dry discs	
Automatic parking brake	●	●	
Hydraulic			
Hydraulic pump	LS	LS + FS	
Flow rate/pressure (l/min - bar)	104 - 250	145 - 250	
Hydraulic tank	110	110	
Hydraulic outlet at the top of the boom	●	●	
Rear hydraulic outlets	○	○	
Cab			
Cab configuration	ECO	ECO	
ASCS Adaptive Stability Control System	Full	Full	
FOPS LIV II cab	●	●	
ROPS cab	●	●	
Cab commands	Electronic joystick control	Electronic joystick control	
Tilting Cab	-	-	
Reverse shuttle	Dual reverse	Dual reverse	
Configuration			
Cab suspension	-	●	
Boom suspension	○	○	
Suspension on axles	-	-	
Work headlights on cab	○	○	
Sun blind	○	○	
Tac-lock	●	●	
Provision for a platform	○	○	
Two floating forks	●	●	
Inching-Control	●	●	
Four-wheel drive	●	●	
Four-wheel steering	●	●	
Three steering modes	●	●	
Standard tyres	400/80-24	400/80-24	
Optional tyres	440/80-24, 445/65-22,5"	440/80-24, 445/65-22,5"	
Stabilisers	Narrow	Narrow	
Turret rotation	-	-	
Type approval as an agricultural tractor	-	-	
Approval with PNEUMATIC braking	-	-	
Approval with HYDRAULIC braking	-	-	
PTO	-	-	
3-point linkage	-	-	

- Not Available
● Standard
○ Optional

Load charts

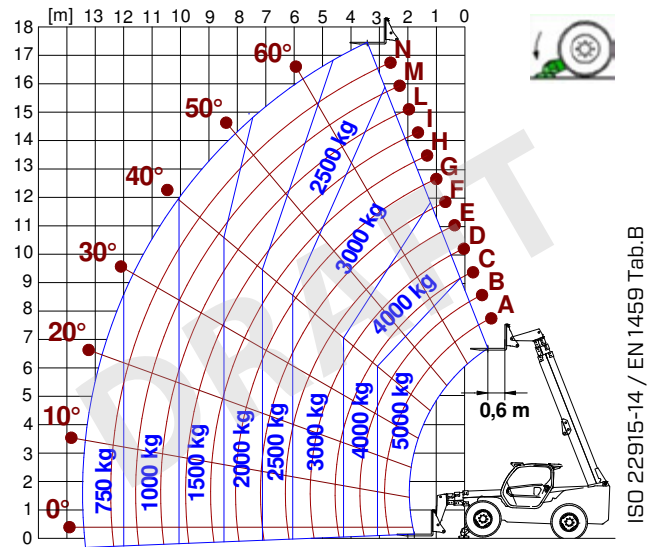
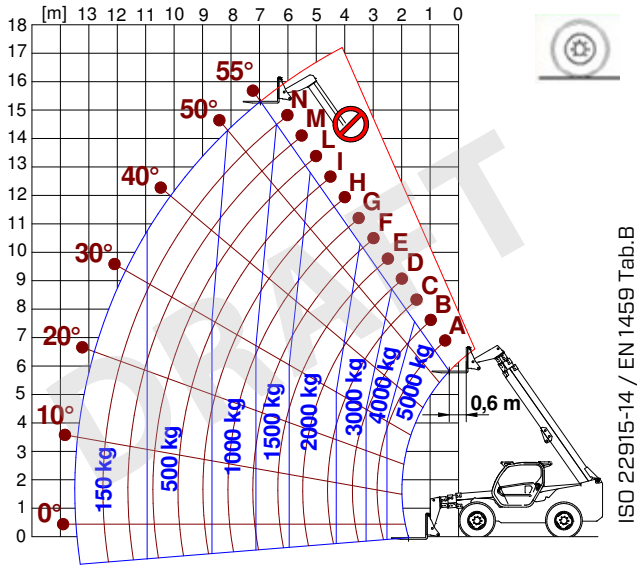

P50.18

Dimensions



	P50.18 PLUS	P50.18 CSTOP	
A (mm)	6190	6190	
B (mm)	1745	1745	
C (mm)	3060	3060	
D (mm)	1385	1385	
E (mm)	5067	5067	
F (mm)	485	485	
H (mm)	2480	2480	
L (mm)	2550	2550	
M (mm)	1010	1010	
P (mm)	2535	2535	
R (mm)	4265	4265	
S (mm)	5611	5611	

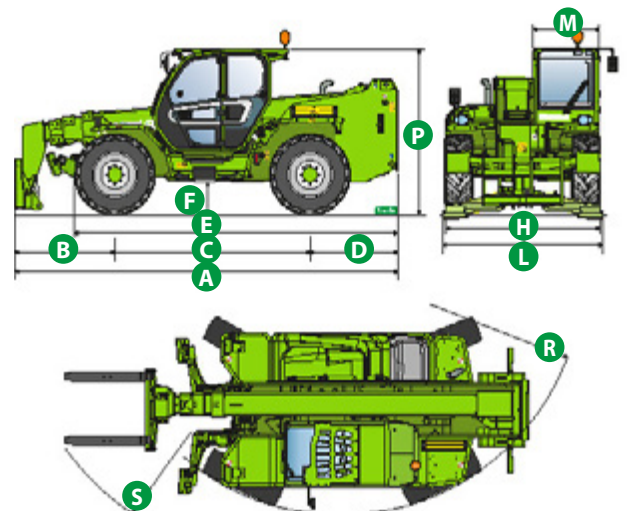

Your Merlo dealer

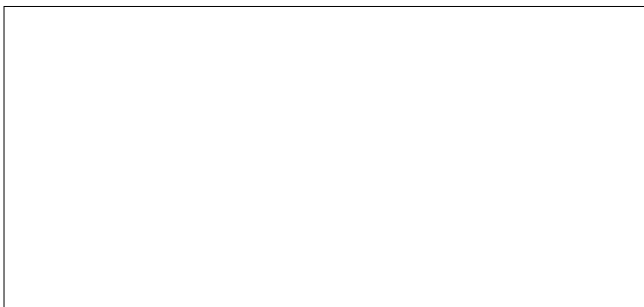

MERLO S.P.A.

Via Nazionale, 9
12010 S. Defendente di Cervasca, (Cuneo) Italia
Tel. +39 0171 614111
Fax +39 0171 684101

info@merlo.com
www.merlo.com

